



BOSCH
Invented for life



24" Compact Laundry Brochure

Volume 2



Commitment to quality.

That's the thinking behind Bosch's precisely-engineered compact washer and dryer. The matching laundry units are the optimal luxury upgrade to any home. Bosch laundry products offer the perfect combination of function and style.

Timeless design.



Design Options

The Bosch compact laundry pairs feature matching washer and dryer designs across the three different series. Design accents unique to each series include white, silver or chrome control knobs and door ring.

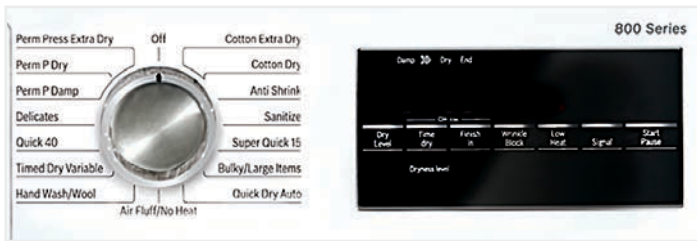

LED Control Panel

The sleek design is apparent in the larger LED control panel which is easy to read and operate.

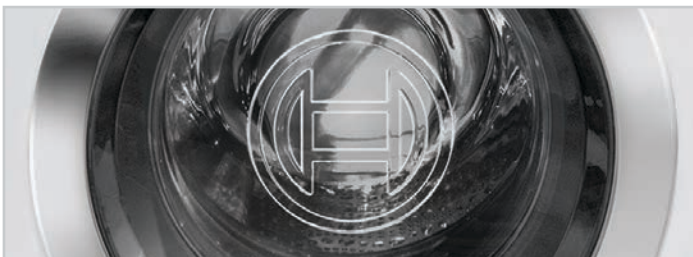

Bosch Magneto

The compact laundry units feature the iconic Bosch Magneto.*

* On 500 Series and 800 Series models only.

Flexible and easy installation.

Combining simple installation with compact laundry solutions, Bosch gives you the flexibility to place the washer and dryer in an area that's most convenient for the home. Bosch compact laundry units can be installed stacked, side-by-side, on pedestals, in a closet or under a counter. The Bosch laundry pair is ideal for small spaces such as urban lofts, guest suites, or secondary and vacation homes.



Flexible accessories



WTZ20410 –
Stationary Stacking Kit



WTZ11400 –
Stacking Kit with Pull Out Tray



WMZ20490 – Washer Pedestal
WMZ20500 – Dryer Pedestal



WMZ20600 – Drying Rack



Reversible door

The 500 and 800 Series dryers offer the option of a reversible door to enhance ease of use and multiple installation choices.

Available on these models:

- ▶ WTG86401UC - 500 Series
- ▶ WTG86402UC - 800 Series

Ventless installation

Bosch condensation dryers are engineered to efficiently reduce drying times. Condensation drying collects the moisture in the hot air and releases it through the water drain via an internal pump. This eliminates the need for external ducting/ venting and blower to exhaust hot air. With no ducting required, installation is made easier, faster and more cost-effective.

ADA Compliant

- Meets ADA height and access requirements when installed on pedestal.
- Meets ADA operable parts requirements for controls, dispenser and lint filter.

Installation cost savings

Bosch washers and dryers not only offer space savings due to their size and the way they are installed, but they also offer cost savings by:

\$ No Additional Power Cord Needed

All power cords are included and assembled with Bosch washers and dryers.

\$\$ No Additional Power Outlets or Wall Receptacles Needed

With the washer plugging into the dryer and only requiring one wall receptacle, the installation of a second wall receptacle is no longer needed.

\$\$\$ No Ducting Needed

Condensation drying requires no ducting. This saves you the cost of running ducting as well as the space behind the dryer needed for flexible duct connections.

\$\$\$\$ No Leak Risk

No smitty pan needed* with the AquaStop® Plus and AquaShield® water leak protection systems. Avoid costly floor and wall damage with these Bosch leak protection systems.

\$\$\$\$\$ ENERGY STAR® Certified

Save on energy and water costs over the life of your project with Bosch ENERGY STAR® certified products.

* Check local building codes for complete requirements.

Quality and performance.



Dirty to dry in 30 minutes

The 800 Series laundry pair features a 15 minute wash and a 15 minute dry cycle. The Bosch 800 Series offers the fastest combined wash and dry time in the industry. The cycle can be used on any small, lightly soiled load, such as five dress shirts.

Water efficiency

Bosch washers exceed the March 2015 ENERGY STAR® water consumption standards and are more efficient than 65% of the washers in the market**.

AquaShield®

The AquaShield® System, on the 500 and 800 Series, consists of a special double-walled inlet hose, which provides protection against water damage.

AquaStop® Plus

The AquaStop® Plus System, on the 800 Series, consists of the AquaShield® double-walled inlet hose with a safety valve and a leak-detector switch in the bottom of the washer to provide extensive protection against water damage. A smitty pan may no longer be required to protect floors and walls from water damage.

ENERGY STAR® certified

All Bosch washers are ultra-efficient. In fact, the 500 and 800 Series laundry pairs are one of the few ENERGY STAR® certified pairs in the 24" market.



SpeedPerfect™ option

SpeedPerfect™ provides up to 40% faster washing time*



Large capacity

Even with a small footprint, our washer features a larger capacity and holds more than most. At 2.2 cubic feet the units have the capacity to wash and dry up to 18 large bath towels. An expansive viewing window and lightweight door make loading and unloading a snap.



Wave-shaped structured drum

The unique wave-shaped structured drum delivers a powerful yet gentle wash. Depending on the cycle, the washer adjusts the direction of the drum rotation, using the steeper edges for heavy duty or shallow edges for delicate fabrics that require gentler care.

* As compared to Perm Press Heavy Soil cycle without SpeedPerfect™.

** Based on the IWF (Integrated Water Factor) listed on the DOE website. April 28, 2015 <http://www.regulations.doe.gov/certification-data/CCMS-79223002113.html>



EcoSilence™ BLDC Motor

The EcoSilence™ BLDC Motor is a brushless motor which makes the SpeedPerfect™ mode quieter than previous Bosch models and provides a more efficient performance cycle.

Quiet operation

The AntiVibration system encompasses sensors in Bosch washers that monitor the load weight and movement of the drum to eliminate imbalances. Additionally, the circular profile design reinforces the structure of the sidewall and increases the stability of the washer. This structure, combined with enhanced insulation, regulates noise levels and reduces vibration up to 30%*, making Bosch washers very quiet throughout the entire wash cycle. Additionally, our dryers are the quietest dryers in the 24" category.**



* Compared to the previous Bosch laundry platform.

** According to published information manufacturers' websites, 24" market (800 Series).

Condensation dryer.

How does a Condensation Dryer work?

The Bosch Condensation Dryer uses an eco-friendly solution to gently dry clothes at an optimal temperature without the need for external ducting. Bosch condensation dryers are engineered to efficiently reduce drying times.



- 1** Ambient air (cool) enters dryer.
 - 2** Ambient air enters heat exchanger and is heated.
 - 3** Ambient air (warm and dry) exits heat exchanger.
 - 4** Process air (heated) enters drum to absorb moisture and dry load.
 - 5** Process air (wet) enters heat exchanger where it is cooled, releasing moisture.
 - 6** Process air (dry) exits heat exchanger.
 - 7** Process air enters heater where it is heated up.
- Drain** Water is collected and pumped to drain.

Step-up features | Washers



WAT28400UC



WAT28401UC



WAT28402UC

300 Series 2.2 cu.ft. 54/73 dBA	500 Series 2.2 cu.ft. 52/72 dBA	800 Series 2.2 cu.ft. 50/71 dBA
15.4 lbs. Capacity (16 bath towels)	+ 17.6 lbs. Capacity (18 bath towels)	17.6 lbs. Capacity (18 bath towels)
Stainless steel wave-shaped structured drum	+ Stainless steel structured drum for washer and dryer	Stainless steel structured drum for washer and dryer
White design accents	+ Premium window design: Bosch Magneto	Premium window design: Bosch Magneto on the door
AntiVibration system	+ Silver design accents: Dial, door trim	+ Chrome design accents: Dial, door trim
EcoSilence™ BLDC Motor	+ AquaShield® Hose	+ AquaStop® Plus Exclusive Water Safety System
SpeedPerfect™		+ Super Quick 15 minute cycle
Large LED display		+ Interior LED light for washer and dryer

Step-up features | Dryers



WTG86400UC



WTG86401UC



WTG86402UC

500 Series 4.0 cu.ft. 67 dBA	500 Series 4.0 cu.ft. 65 dBA	800 Series 4.0 cu.ft. 63 dBA
15.4 lbs. Capacity (16 bath towels)	+ 17.6 lbs. Capacity (18 bath towels)	17.6 lbs. Capacity (18 bath towels)
Galvalume drum material	+ Stainless steel structured drum for washer and dryer	Stainless steel structured drum for washer and dryer
15 Programs / 6 Options	+ Premium window design: Bosch Magneto	Premium window design: Bosch Magneto on the door
Washer plugs into the dryer	+ Reversible dryer door	+ Reversible dryer door
White design accents	+ Silver design accents: Dial, door trim	+ Chrome design accents: Dial, door trim
Power cord included		+ Super Quick 15 minute cycle
Large LED display		+ Interior LED light
		+ AntiShrink Cycle

24" washer technical details.

Series	300 Series Washer	500 Series Washer	800 Series Washer
Color			
White	WAT28400UC	WAT28401UC	WAT28402UC
Core Features			
Capacity DOE (cu. ft.)	2.2 cu. ft.	2.2 cu. ft.	2.2 cu. ft.
Washing Capability	16 towels	18 towels	18 towels
Spin Speed	1,400 rpm	1,400 rpm	1,400 rpm
Silence Rating – Washing	54/73 dBA	52/72 dBA	50/71 dBA
Number of Wash Cycles	15	15	15
Number of Wash Options	6	6	6
Efficiency			
ENERGY STAR® Certified	■	■	■
Energy Use	84 kWh/yr	84 kWh/yr	84 kWh/yr
Integrated Modified Energy Factor (IMEF)	2.2	2.2	2.2
Integrated Water Factor (IWF)	3.6	3.6	3.6
ENERGY STAR® Water Consumption Standards	■	■	■
Annual Water Consumption (gallons/year)	2,320	2,320	2,320
Design Elements			
Display	Large LED Display	Large LED Display	Large LED Display
Cabinet	White	White	White
Dial	White	Silver	Chrome
Door	White	Silver	Chrome
Bosch Magneto Drum	■	■	■
Drum	Stainless Steel, Structured Drum	Stainless Steel, Structured Drum	Stainless Steel, Structured Drum
Cycles			
Cotton Normal	15	15	15
Cotton Light Soil	■	■	■
Permanent Press	■	■	■
Permanent Press Heavy Soil	■	■	■
Permanent Press Light Soil	■	■	■
Sanitize	■	■	■
Jeans	■	■	■
Quick Wash 30 min.	■	■	■
Heavy Duty	■	■	■
Delicates	■	■	■
Hand wash/Wool	■	■	■
Allergen	■	■	■
Towels	■	■	■
Super Quick 15 min.	■	■	■
Bulky/Large Items	■	■	■
Whitest Whites	■	■	■
Drum Clean	■	■	■
Drain	■	■	■
Rinse/Spin	■	■	■
Options			
SpeedPerfect™	6	6	6
Extra Rinse	■	■	■
Prewash	■	■	■
Temperature Selection	■	■	■
Spin Speed Selection	■	■	■
Finish In	■	■	■
Advanced Features			
AquaStop® Plus Leak Protection	■	■	■
AquaShield® Leak Protection	■	■	■
Reinforced Water Supply Hoses	■	■	■
AntiVibration System	■	■	■
Tub Motion Load Sensors	■	■	■
Control Types	Electronic	Electronic	Electronic
Interior Drum LED Light	■	■	■
Stainless Steel “Wave” Structured Drum	■	■	■
Internal Water Heater	■	■	■
Sensor Controlled Washing	■	■	■
Adjustable Signal	■	■	■
Dimensions			
Product HxWxD	33 ¼" x 23 ½" x 24 ¼"	33 ¼" x 23 ½" x 25"	33 ¼" x 23 ½" x 25"
Packaging HxWxD	34 ¼" x 25 ¼" x 26 ¾"	34 ¼" x 25 ¼" x 26 ¾"	34 ¼" x 25 ¼" x 26 ¾"
Minimum Staking Height	67 ¾"	67 ¾"	67 ¾"
Leveling Legs/Height Adjustment Range	Yes, ½"	Yes, ½"	Yes, ½"
Weight	158 lbs.	160 lbs.	160 lbs.
Shipping Weight	161 lbs.	164 lbs.	164 lbs.
Door Opening (Angle)	165°	180°	180°
Technical Information			
Supply Voltage	208/220-240 V	208/220-240 V	208/220-240 V
Frequency	60 Hz	60 Hz	60 Hz
Amperage	12 A	12 A	12 A
Required Circuit Amperage	30 A	30 A	30 A
Connected Load	2,300 W	2,300 W	2,300 W
Plug Included	240 V 3-prong	240 V 3-prong	240 V 3-prong
Plug into Dryer	■	■	■
Plug Type	NEMA 6-15 (3-prong)	NEMA 6-15 (3-prong)	NEMA 6-15 (3-prong)
Power Cord Included	Yes	Yes	Yes
Power Cord Length	63"	63"	63"
Drain Hose Length	57"	57"	57"
Inlet Hose Length	47"	59"	59"

24" dryer technical details.

Series	300 Series Condensation Dryer	500 Series Condensation Dryer	800 Series Condensation Dryer
Color			
White	WTG86400UC	WTG86401UC	WTG86402UC
Core Features			
Capacity (cu. ft.)	4.0 cu. ft.	4.0 cu. ft.	4.0 cu. ft.
Drying Capability	16 towels	18 towels	18 towels
Silence Rating	67 dBA	65 dBA	63 dBA
Number of Drying Programs	15	15	15
Number of Drying Options	6	6	6
Efficiency			
ENERGY STAR® Certified		■	■
Energy Use	320 kWh/yr	311 kWh/yr	311 kWh/yr
Design Elements			
Display	Large LED Display	Large LED Display	Large LED Display
Cabinet	White	White	White
Dial	White	Silver	Chrome
Door	White	Silver	Chrome
Bosch Magneto		■	■
See-thru Door		■	■
Drum	Galvalume Drum	Stainless Steel, Structured Drum	Stainless Steel, Structured Drum
Programs	15	15	15
Cotton Extra Dry	■	■	■
Cotton Dry (Regular)	■	■	■
Permanent Press Extra Dry	■	■	■
Permanent Press Dry	■	■	■
Permanent Press Damp	■	■	■
Jeans	■	■	■
Quick Dry Auto	■	■	■
Air Fluff/No Heat	■	■	■
Time Dry Variable	■	■	■
Quick 40	■	■	■
Delicates	■	■	■
Heavy Duty	■		■
Super Quick 15 min			■
Sanitize	■	■	■
Hand Wash/Wool	■	■	■
Towels	■	■	■
AntiShrink			■
Bulky/Large Items		■	■
Options	6	6	6
Time Dry	■	■	■
Dry Level	■	■	■
Finish in	■	■	■
Low Heat	■	■	■
WrinkleBlock®	■	■	■
Signal	■	■	■
Advanced Features			
Control Types	Electronic	Electronic	Electronic
Stainless Steel Structured Drum		■	■
WrinkleBlock®	Up to 90 min.	Up to 90 min.	Up to 90 min.
Fully Electronic Moisture Sensor	■	■	■
Reversible Door		■	■
Interior Drum LED Light		■	■
Lint Filter Indicator	■	■	■
Dimensions			
Product HxWxD	33 ¼"x 23 ½"x 25"	33 ¼"x 23 ½"x 25"	33 ¼"x 23 ½"x 25"
Packaging HxWxD	34 ¼"x 25 ¼"x 26 ¾"	34 ¼"x 25 ¼"x 26 ¾"	34 ¼"x 25 ¼"x 26 ¾"
Minimum Staking Height	67 ¾"	67 ¾"	67 ¾"
Leveling Legs/Height Adjustment Range	Yes, ¾"	Yes, ¾"	Yes, ¾"
Weight	99 lbs.	99 lbs.	99 lbs.
Shipping Weight	101 lbs.	101 lbs.	101 lbs.
Door Opening (Angle)	180°	180°	180°
Technical Information			
Supply Voltage	208/220-240 V	208/220-240 V	208/220-240 V
Frequency	60 Hz	60 Hz	60 Hz
Connected Load	2,800 W	2,800 W	2,800 W
Amperage	13 A	13 A	13 A
Required Circuit Amperage	30 A	30 A	30 A
Air-Flow-Intake	118 CFM (200 m³/h)	118 CFM (200 m³/h)	118 CFM (200 m³/h)
Plug Included	NEMA 14-30 (4-prong)	NEMA 14-30 (4-prong)	NEMA 14-30 (4-prong)
Type	Electric	Electric	Electric
Drain Pump and Hose	Yes, Dryer and Washer Drain Hoses Routed Together	Yes, Dryer and Washer Drain Hoses Routed Together	Yes, Dryer and Washer Drain Hoses Routed Together

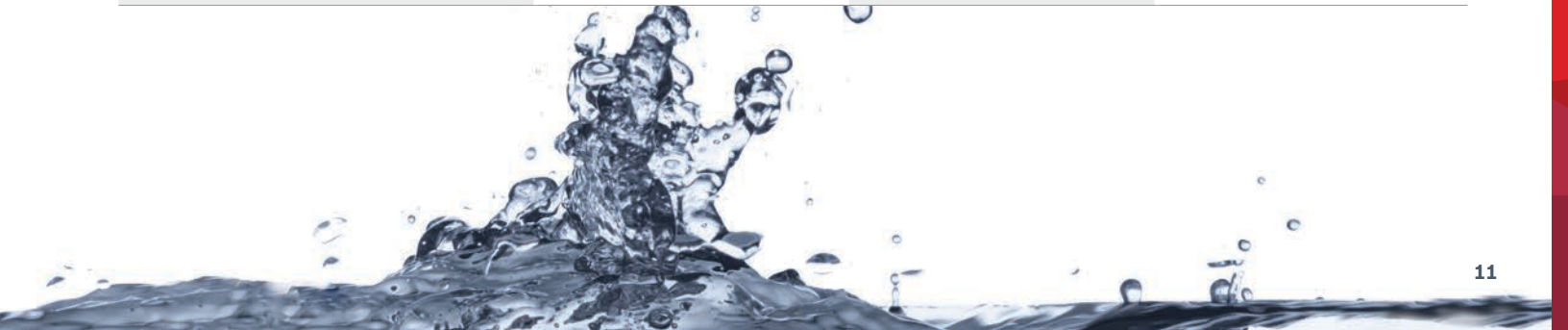

300 Series dimensions and installation.

300 Series Washer (WAT28400UC)

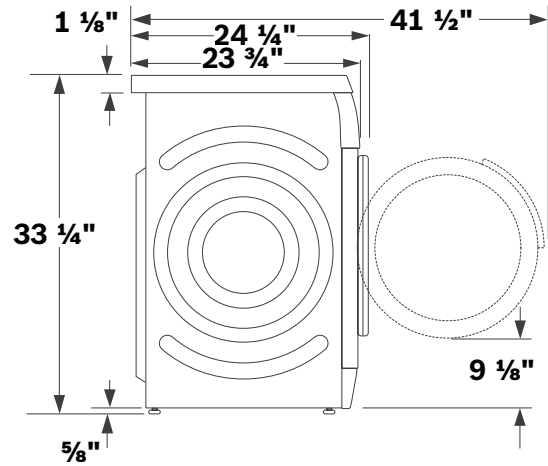
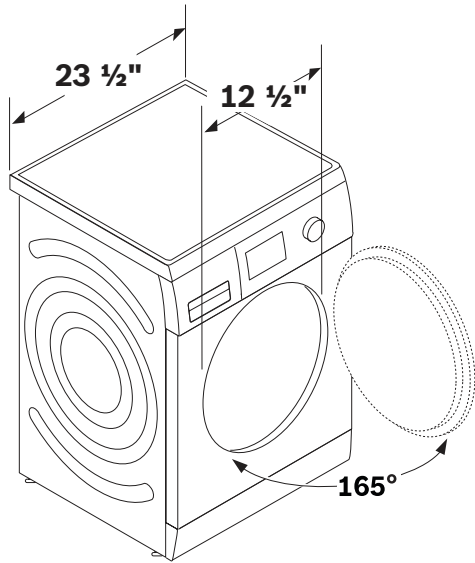

Washer plugged into the dryer

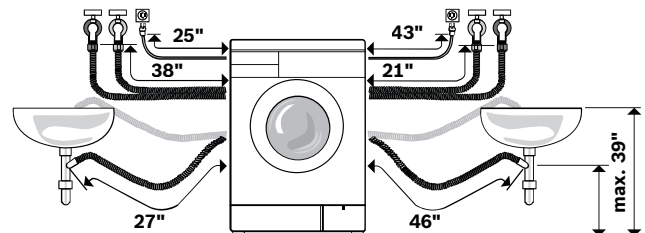
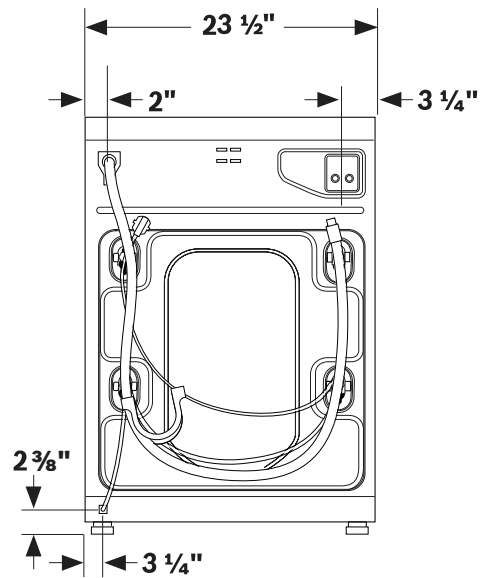
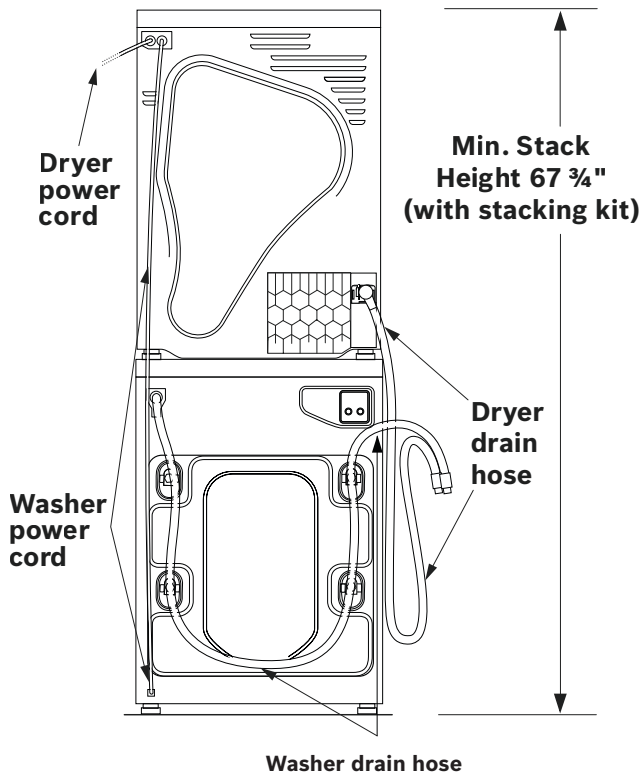

300 Series Dryer (WTG86400UC)

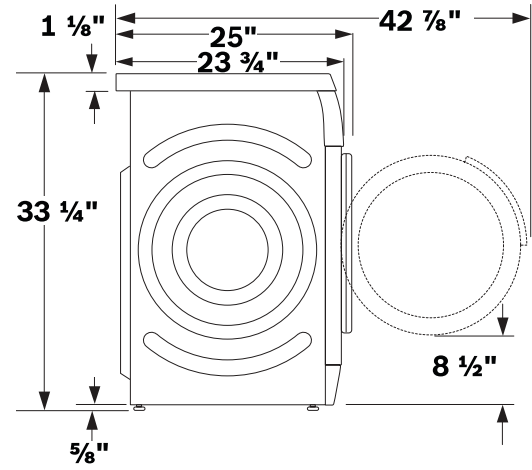
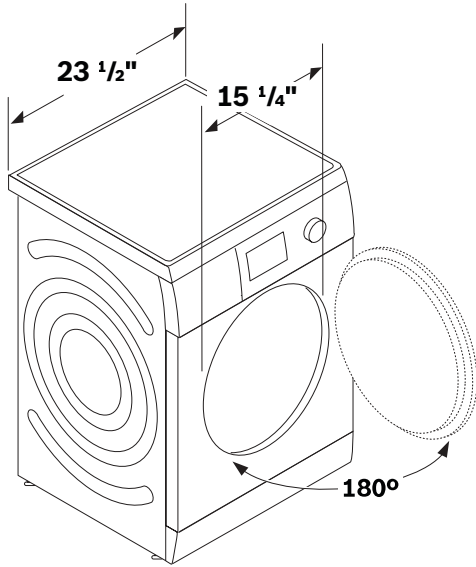

Washer plugged into the dryer

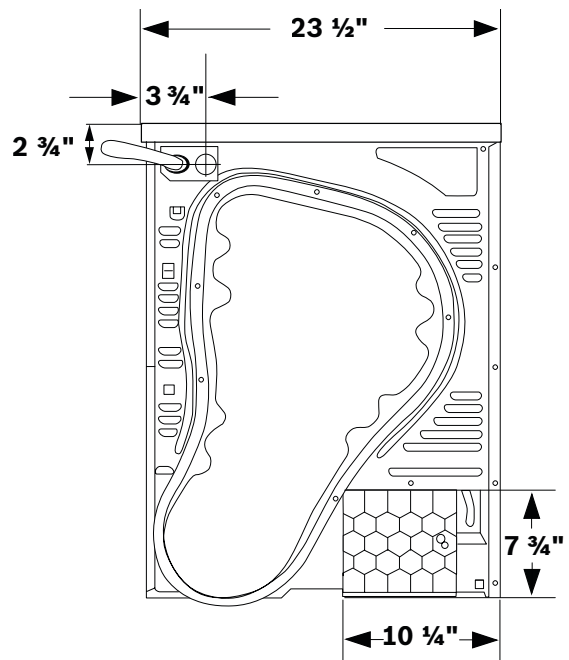
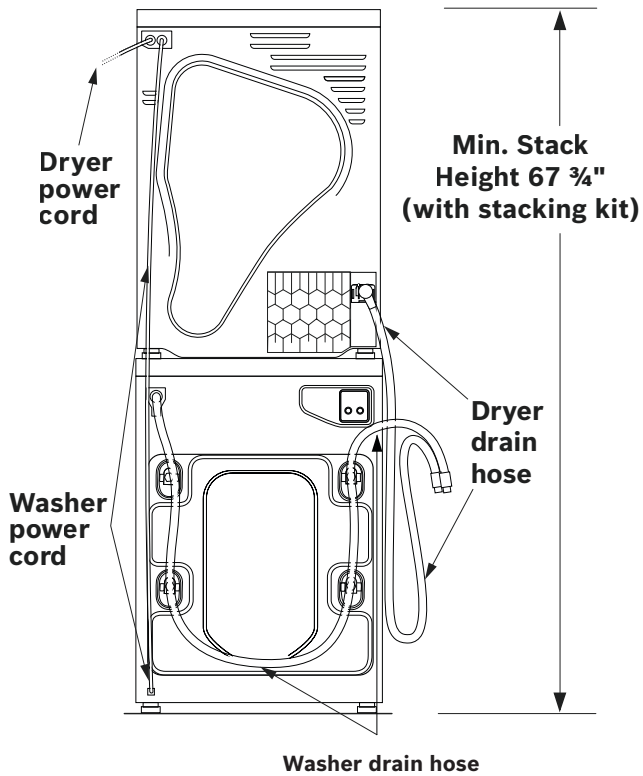

500 Series and 800 Series dimensions and installation.

500 Series Washer (WAT28401UC) and 800 Series Washer (WAT28402UC)

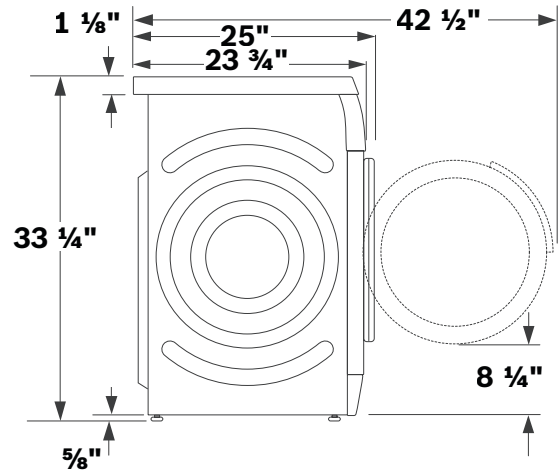
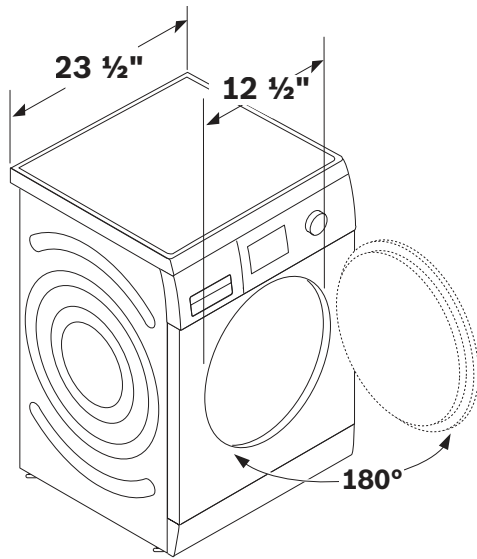

Washer plugged into the dryer

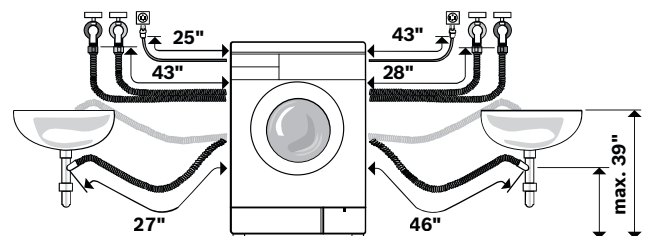
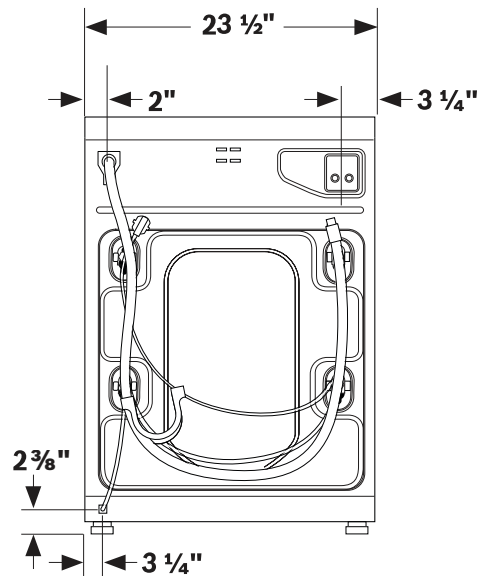
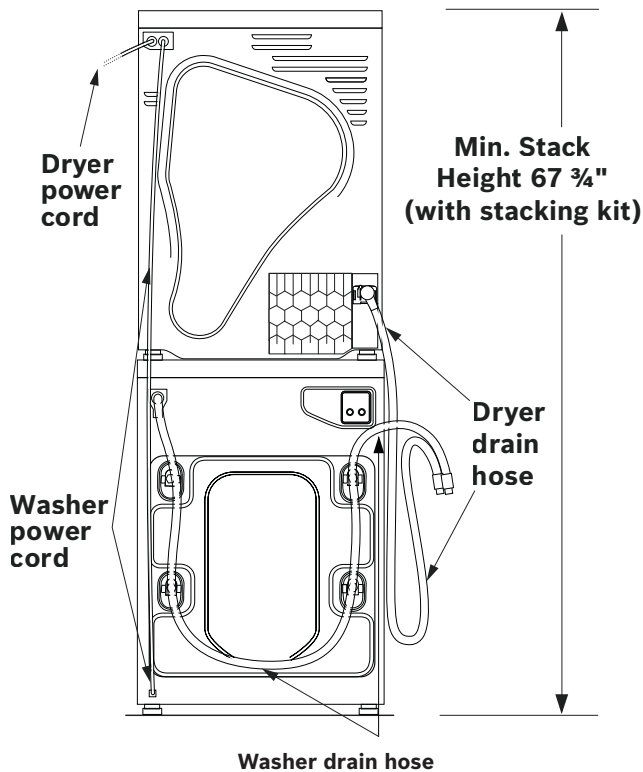

500 Series Dryer (WTG86401UC) and 800 Series Dryer (WTG86402UC)

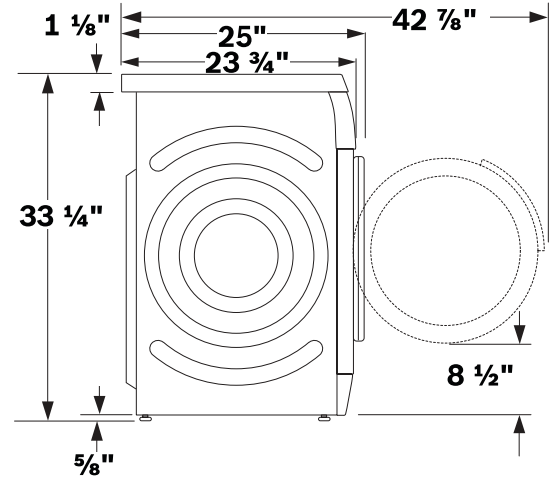
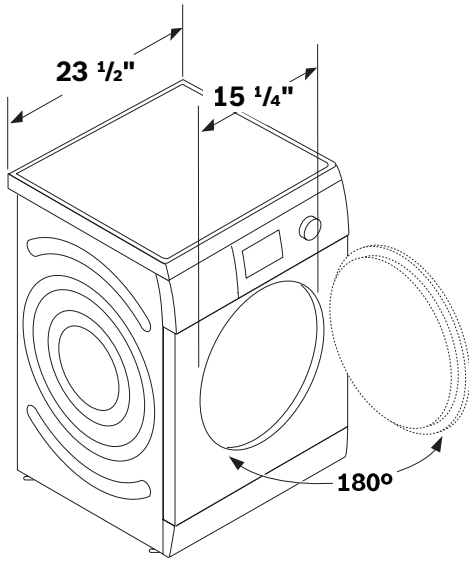

Washer plugged into the dryer

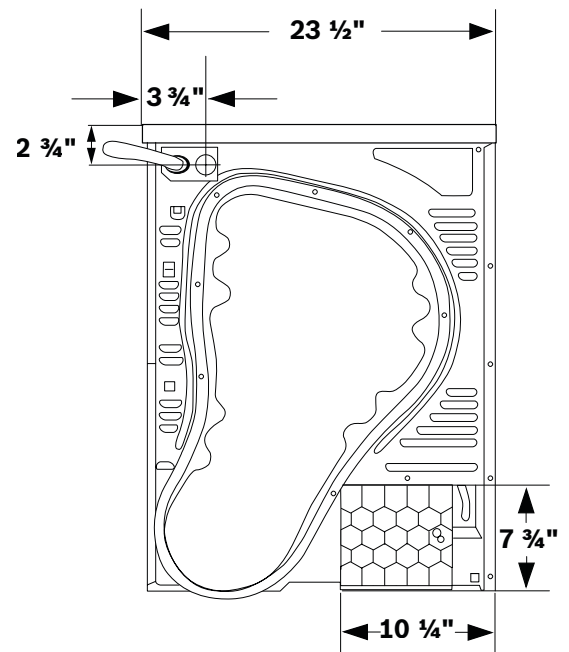
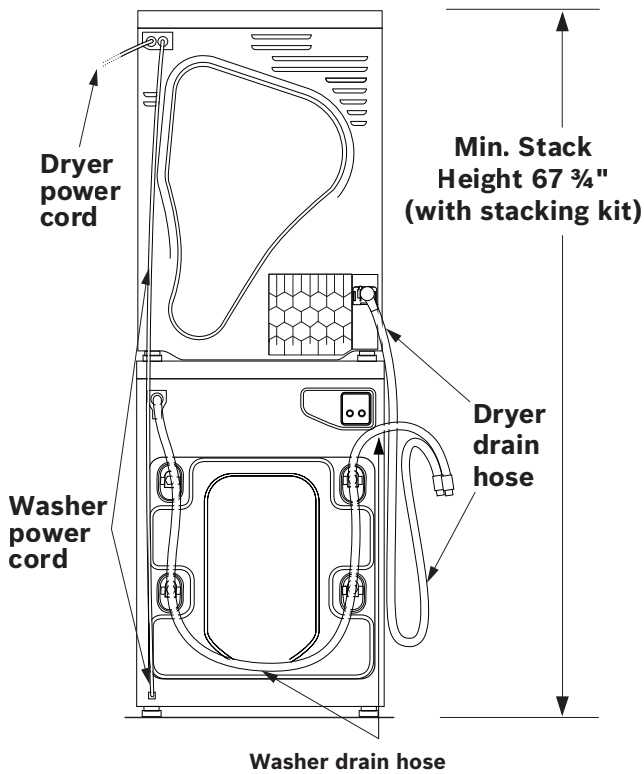

Dimensions and installation.

Enclosure dimensions

Closet: Stacked

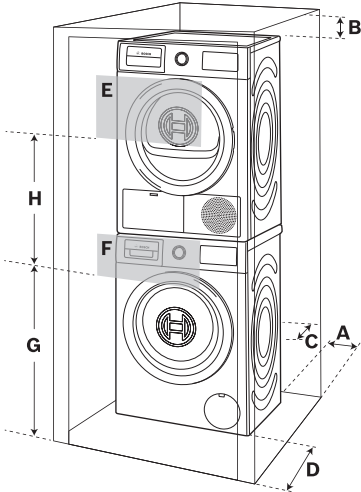

Closet: Stand Alone (shown) or Side by Side

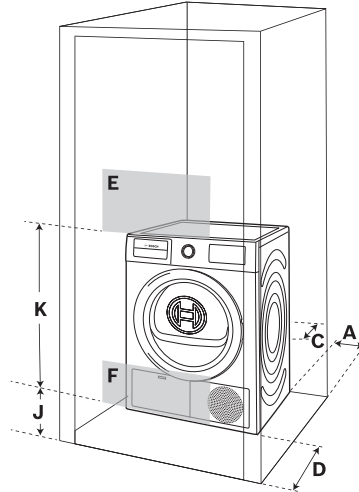

Clearance Requirements (Minimum)

A Both Sides	5/8 in.
B Top	6 1/4 in.
C Rear	2 1/2 in.
D Front	2 1/2 in.

Ventilation Area (Minimum)

E Top	63 sq. in.
F Bottom	63 sq. in.

Vent Spacing

G	37 in.
H	26 in.
J	3 in.
K	29 in.

Under Counter: (Preferred)

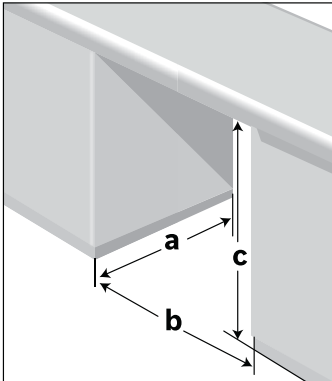

Front of the appliance fully open. No doors or coverings.

Under Counter: (Less Preferred)

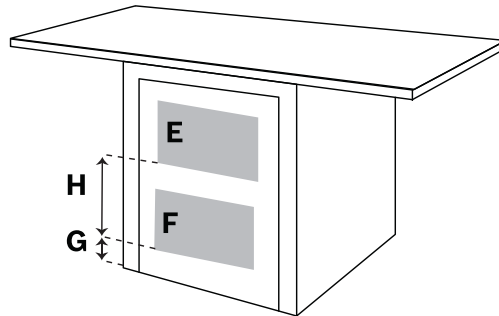

If the front of the appliance is covered, ventilation openings must be installed as shown and front/rear clearances adhered to according to closet installations. (see spec sheet)

Minimum Opening Dimensions

a	28 in.
b	23 7/8 in.
c	34 1/2 in.

E & F are Minimum Area Sizes

E	63 sq. in.
F	63 sq. in.

G & H Actual Spacing Dimensions for Min. Open Area Sizes

G	3 in.
H	14 in.



Customer service.

Service you can trust 100%.

The Bosch Customer Support Team is ready to help. Please don't hesitate to contact us if you have questions on our product line, need advice about use and care, or would like to purchase parts and accessories. We are ready to assist you.

Website:

- ▶ How-to Videos
- ▶ Frequently Asked Questions
- ▶ Filters, Accessories and Parts
- ▶ Owner Manuals
- ▶ Product Registration
- ▶ Find a Dealer
- ▶ Find a Bosch Authorized Servicer

Phone:

- ▶ 24-Hour Call Center Access
- ▶ English, French, Spanish

1-800-944-2904

Warranty:

- ▶ One-year Limited Warranty on all Bosch Appliances

Bosch Home Appliances US:

www.bosch-home.com/us

Bosch Home Appliances Canada:

www.bosch-home.ca

Important note: Please refer to installation instructions prior to making cutout. BSH reserves the absolute and unrestricted right to change product materials and specifications, at any time, without notice. Consult the product's installation instructions for final dimensional data and other details. Applicable product warranty can be found in accompanying product literature or you may contact your account manager for further details.

For more information on our entire line of products, go to www.bosch-home.com/us or call 1-800-944-2904

Warranty.

Laundry

Limited warranty, entire appliance, parts and labor (1 year).

Electronics and motors

Extended limited warranty from date of purchase (2 years)

Bosch will repair or replace, free of charge, any printed circuit boards, drive motor or component part of the drive motor that proves defective under conditions of normal home use during the first two years from the date of purchase, labor charges excluded.

Warranty Note: Bosch warrants that the Product is free from defects in materials and workmanship for a period of three hundred and sixty-five (365) days from the date of purchase. The foregoing timeline begins to run upon the date of purchase, and shall not be stalled, tolled, extended, or suspended, for any reason whatsoever. This Product is also warranted to be free from cosmetic defects in material and workmanship, such as scratches of stainless steel, paint/porcelain blemishes, chips, dents, or other damage to the finish of the Product, for a period of thirty (30) days from the date of purchase or closing date for new construction. This cosmetic warranty excludes slight color variations due to inherent differences in painted and porcelain parts, as well as differences caused by kitchen lighting, product location, or other similar factors. This cosmetic warranty specifically excludes any display, floor, "As Is", or "B" stock appliances.



Bosch Home Appliances

1901 Main St., Suite 600
Irvine, CA 92614

www.bosch-home.com/us
www.bosch-home.ca

24-hour call center support
in English, French & Spanish:
1-800-944-2904

©2017 BSH Home Appliances Corporation
17-BOS-0818 3/17 DG